

Conco articulated jib crane with air plumbing

Designed to reach into inaccessible areas and tight work spaces. This jib can be equipped with an air-operated hoist or CM Max balancer for smooth, infinitely variable control (hoist/balancer not included). It features:



- Two 360° pivot arms that can reach and operate in confined areas where standard jib cranes cannot
- Ease of movement and accurate positioning assured with heavy roller bearings in both arms
- Internal pneumatic piping for addition of other lifting devices such as the Conco Airlift
- Versatile as a floor or overhead mounted unit
- Capacities to one ton and work envelopes to 32 feet in diameter
- One-year warranty
- Made in U.S.A.

Specifications light duty

Model No.	Cap.* (lbs.)	Reach (ft.)	A (in.)	B (in.)	C (in.)	D (in.)	E (in.)	F (in.)
AJ310-8	310	8	56	40	3 ⁷ / ₈	106 ¹ / ₄	90	18 ¹ / ₈
AJ280-9	280	9	63	45	3 ⁷ / ₈	106 ¹ / ₄	90	18 ¹ / ₈
AJ250-10	250	10	70	50	3 ⁷ / ₈	106 ¹ / ₄	90	18 ¹ / ₈
AJ230-11	230	11	77	55	3 ⁷ / ₈	106 ¹ / ₄	90	18 ¹ / ₈
AJ210-12	210	12	84	60	3 ⁷ / ₈	106 ¹ / ₄	90	18 ¹ / ₈
AJ190-13	190	13	91	65	3 ⁷ / ₈	106 ¹ / ₄	90	18 ¹ / ₈
AJ180-14	180	14	98	70	3 ⁷ / ₈	106 ¹ / ₄	90	18 ¹ / ₈
AJ170-15	170	15	105	75	3 ⁷ / ₈	106 ¹ / ₄	90	18 ¹ / ₈

To convert to ceiling mount, change suffix on model to C.

* Include hoist weight to determine capacity.

Specifications standard duty

Model No.	Cap.* (lbs.)	Reach (ft.)	A (in.)	B (in.)	C (in.)	D (in.)	E (in.)	F (in.)
AJ1250-8	1250	8	56	40	6 ¹ / ₄	124 ¹ / ₂	98	31 ⁵ / ₈
AJ1110-9	1110	9	63	45	6 ¹ / ₄	124 ¹ / ₂	98	31 ⁵ / ₈
AJ1000-10	1000	10	70	50	6 ¹ / ₄	124 ¹ / ₂	98	31 ⁵ / ₈
AJ910-11	910	11	77	55	6 ¹ / ₄	124 ¹ / ₂	98	31 ⁵ / ₈
AJ835-12	835	12	84	60	6 ¹ / ₄	124 ¹ / ₂	98	31 ⁵ / ₈
AJ770-13	770	13	91	65	6 ¹ / ₄	124 ¹ / ₂	98	31 ⁵ / ₈
AJ715-14	715	14	98	70	6 ¹ / ₄	124 ¹ / ₂	98	31 ⁵ / ₈
AJ665-15	665	15	105	75	6 ¹ / ₄	124 ¹ / ₂	98	31 ⁵ / ₈

To convert to ceiling mount, change suffix on model to C.

* Include hoist weight to determine capacity.

Specifications heavy duty

Model No.	Cap.* (lbs.)	Reach (ft.)	A (in.)	B (in.)	C (in.)	D (in.)	E (in.)	F (in.)
AJ2000-8	2000	8	56	40	11 ³ / ₄	134 ¹ / ₂	98	44 ¹ / ₂
AJ1785-9	1785	9	63	45	11 ³ / ₄	134 ¹ / ₂	98	44 ¹ / ₂
AJ1600-10	1600	10	70	50	11 ³ / ₄	134 ¹ / ₂	98	44 ¹ / ₂
AJ1460-11	1460	11	77	55	11 ³ / ₄	134 ¹ / ₂	98	44 ¹ / ₂
AJ1340-12	1340	12	84	60	11 ³ / ₄	134 ¹ / ₂	98	44 ¹ / ₂
AJ1256-13	1256	13	91	65	11 ³ / ₄	134 ¹ / ₂	98	44 ¹ / ₂
AJ1150-14	1150	14	98	70	11 ³ / ₄	134 ¹ / ₂	98	44 ¹ / ₂
AJ1071-15	1071	15	105	75	11 ³ / ₄	134 ¹ / ₂	98	44 ¹ / ₂
AJ1000-16	1000	16	112	80	11 ³ / ₄	134 ¹ / ₂	98	44 ¹ / ₂

To convert to ceiling mount, change suffix on model to C.

* Include hoist weight to determine capacity.

* ⚠ WARNING

Overloading and improper use can result in injury.

To avoid injury:

- Do not exceed working load limit, load rating or capacity.
- Do not use to lift people or loads over people.
- Use only alloy chain for overhead lifting.
- Read and follow all instructions.

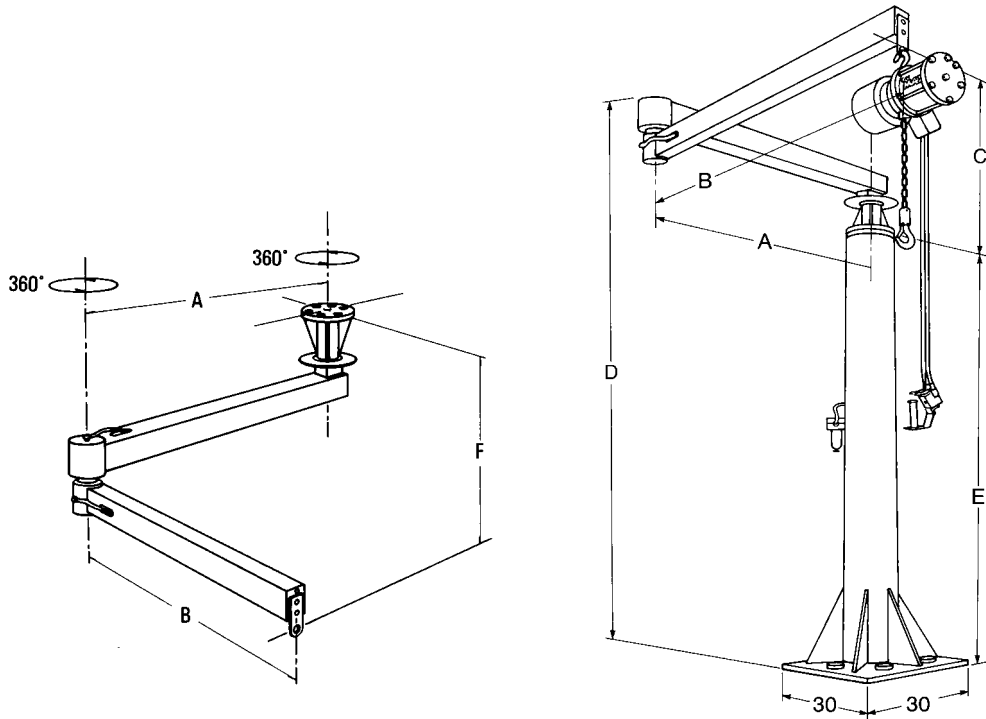

Model number	Maximum capacity (lbs.)	Radius of reach (ft.)
LIGHT DUTY SERIES (Standard pedestal 90")		
AJ310-8P	310	8
AJ280-9P	280	9
AJ250-10P	250	10
AJ230-11P	230	11
AJ210-12P	210	12
AJ190-13P	190	13
AJ180-14P	180	14
AJ170-15P	170	15
STANDARD DUTY SERIES (Standard pedestal 98")		
AJ1250-8P	1250	8
AJ1110-9P	1110	9
AJ1000-10P	1000	10
AJ910-11P	910	11
AJ835-12P	835	12
AJ770-13P	770	13
AJ715-14P	715	14
AJ665-15P	665	15
HEAVY DUTY SERIES (Standard pedestal 98")		
AJ2000-8P	2000	8
AJ1785-9P	1785	9
AJ1600-10P	1600	10
AJ1460-11P	1460	11
AJ1340-12P	1340	12
AJ1236-13P	1236	13
AJ1150-14P	1150	14
AJ1071-15P	1071	15
AJ1000-16P	1000	16

To convert to ceiling mount, change suffix on model to C.

* Include hoist weight to determine capacity.